

## KACKAR Serie Multi-Jet Wet Dial Water Meter for Cold Water



### Main Characteristics:

Approved in accordance with MID  
Multi-Jet wet dial register type with vane-wheel  
Brass housing material  
Durable internal removable strainer and non return valve  
Removable measuring mechanism  
Metrological range -horizontal- R160 (Class C)  
360° rotating lid  
Horizontal installation  
Magnetic transmission  
Register cap made of brass  
High resistance to water impurities  
Hermetically sealed register (IP68)  
Available for optical direct reading  
Electrostatic e/p powder painted  
External adjustable screw  
Water temperature up to 50°C  
(QR) Code to send data for viewing - optional  
Spare parts and service available for 10 years  
2 years of guarantee

### Approvals:

EC type-examination certificate in conformity with

- 2014/32/EU (MID) MI-001 Water Meter
- OIML R49-1 :2006
- EN 14154:2005+A2
- ISO 4064:2015
- EC Type Examination Certificate (TCM . 142 / 14 - 5169)
- The Quality Assurance of Production Process (Module D)
- ISO 9001:2015
- ISO 14001:2015
- ISO 45001:2018
- ISO 27001:2013

### Applications:

For the consumption measuring of cold potable water up to 50°C. Working pressure 16 bar (PN16), min. static pressure test 25 bar for 15 mins., 32 bar for 1 mins. Its reliability, resistance to bad water quality and noiseless operation will satisfy both end users and network managers. Meter also keeps its metrological accuracy for many years of operation, even in very difficult working conditions.

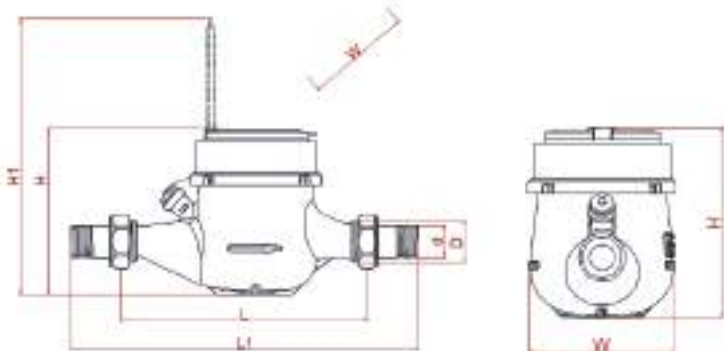

	Nominal Daimeter	Dn	15	20	
		Size	Inch	Inch	
Dimension / Weight	Overall Length Without Connectors	L	mm	165(*)	190(**)
	Overall Length With Connectors	L1	mm	230	260
	Thread Meter GxB	D	Inch	¾"	1"
	Thread Connector	d	Inch	½"	¾"
	Total Height	H	mm	106	95,8
	Total Height (With Lid)	H1	mm	170	160,5
	Width Approx	W	mm	84,5	84,5
	Weight Approx	*	kg	1,04	0,94
	Package Without Connectors	*	kg	1,08	0,98
	Package With Connectors	*	kg	1,23	1,13
	Box Dimension (1 unite)	*	cm	19x10x9	19x10x9
	Package Dimension (10 unite)	*	cm	49x23x20	49x23x20
	Quantity Per Package	*	unite	10	10

(\*) Also available in length 190 mm

(\*\*) Also available in length 165 mm

Threading : EN ISO 228-1 : 2003

### Marking:

The manufacturer's trade mark, Nominal flow rate (Q3), Metrological ratio (R), Nominal size of the meter, Maximum working pressure (MAP), Pressure head loss class (ΔP), Type of the meter (Model), EC-type examination certificate number, Year of manufacturing, Mounting position, Maximum water temperature (T), CE marking, Metrology marking, Notified body number from D and F module, Volume unite of the index (m3) according to the MID 2014/32/EU directive on measuring instruments are printed on the dial.

Optional customized meter marking purchaser's logo or tender number, or QR code, serial number.

Markings which are clearly visible, readable and of permanent and non-deleteable nature may vary depending on particular markets or metrological specifications.

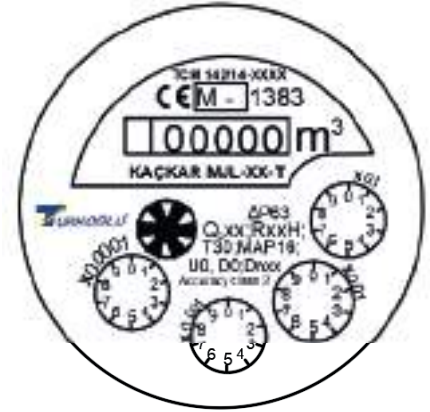

### Installation and Operating Instruction:

Meter must be installed in a low point of the pipeline with the arrow cast on the body showing direction of the water flow. All pipework must be flushed out to remove all impurities before fitting the water meter. An upstream stop valve or ball valve is recommended to allow installation and removal of the water meter. When connecting the meter with the meter network, the upstream stop valve or ball valve must be opened slowly so that the meter fills the meter as smoothly as possible. No special maintenance is required.

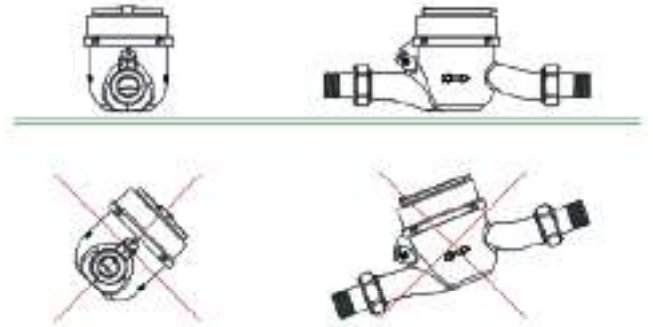

### Typical Accuracy Curve:

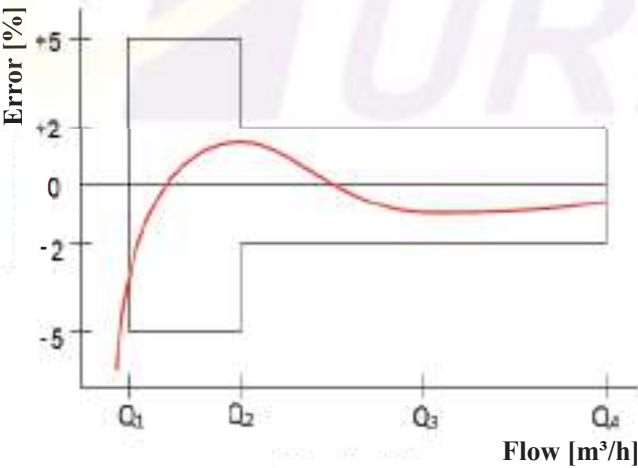

Q<sub>1</sub> = Minimum Flowrate      Q<sub>3</sub> = Permanent Flowrate  
 Q<sub>2</sub> = Transitional Flowrate      Q<sub>4</sub> = Overload Flowrate

### Typical Head Loss Curve:

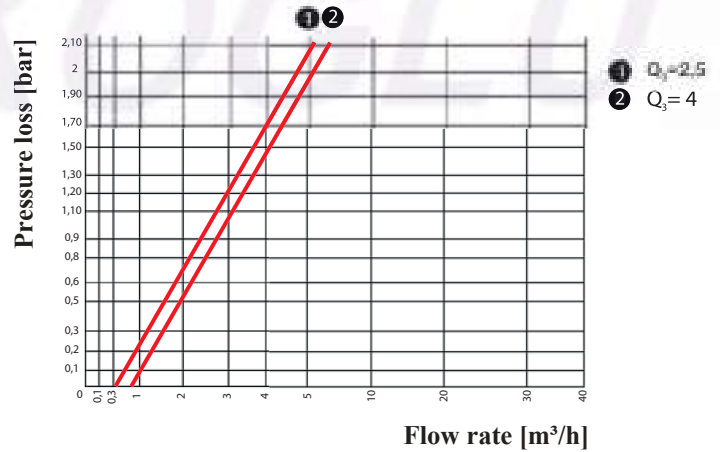

## Tampering Protection and Sealing (Optional):

### • Anti-Tampering butterfly seal for water meter

Pented butterfly seal consists mainly of three parts: transparent body, colored butterfly inner part and stainless steel sealing wire. Transparent body is made of polycarbonate (PC) material, colorful butterfly inner part is made of polyoximethylene (POM) which can not be removed without breaking from mounted inside. The inner part mounted inside the cylindrical body shall be non-reversible and unidirectional. Sealing wire made of AISI304 stainless steel are produced by twisting 7 pieces of  $\varnothing$  0.23mm wire on top of each other. The butterfly seal can be used once against tampering in water meters. Optional: Laser printed serial number and company logo could be added on the body based on quantity.

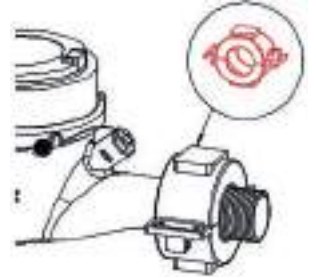
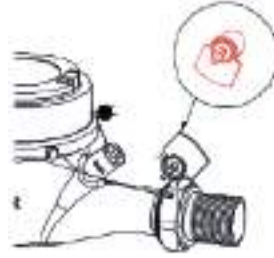

### • Anti-Tampering plastic seal for water meter connectors

Plastic seal consists of two equal parts. They are made of polycarbonate (PC) material which has non-flammable, chemicals, salts, weather and ultra-violet resistant. Thickness is min.2,00 mm and not easily deform and it can not opened without breaking. There are holes on the locking mechanism suitable for the passage of the sealing wire after locking.

The materials to be used of both seals are recyclable, and the contents are not contain harmful substances to human health and environment.

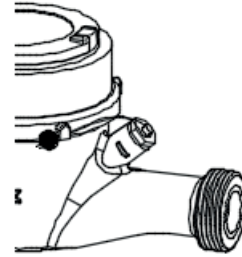

### • Meter Seals

The meter is sealed by sealing materials which are stainless steel wire 1.00 mm thickness - optional (covered with plastic) and aluminium seal.

Stainless Steel Seal

	Nominal Diameter (DN)	DN	mm	15	20	
		Size	Inch	½"	¾"	
Performance Data	Metrological Data	Maximum Flow Rate (m <sup>3</sup> /h)	Q4	≤3.13	≤5.00	
		Nominal Flow Rate (m <sup>3</sup> /h)	Q3	≤2.50	≤4.00	
		Transitional Flow Rate (l/h) Tolerance ±2%	Q2	≤0.0200	≤0.0320	
		Minimum Flow Rate (l/h) Tolerance ±5%	Q1	≥0.0125	≥0.0200	
		Measuring Range - Horizontal (R-Class)	Q3 / Q1	200 H (Class C)		
		Measuring Transitional Flow Rate	Q2 / Q1	1.6		
		Measuring Maximum Flow Rate	Q4 / Q3	1.25		
		Accuracy Class		2		
		Technical Data	Maximum Permissible Error Fort The Lower Flow Rate Zone	(MPE1)	±5%	
				(MPEu)	±2 % for water having a temperature ≤30 °C ±3 % for water having a temperature >30 °C	
Temperature Class	T °C		T30 and T50			
Water Pressure Classes	MAP (Bar)		16			
Pressure - Loss Classes	Δ P (Bar)		0,63			
Max. Indicating Range	[m <sup>3</sup> ]		99 999			
Resolution Of The Indicating Device	[litre]		0,05			
Installation Positions			H			
Flow Profile Sensitivity Classes		U0 D0				

## Third Party Inspection Company (Optional)

Third Party Inspection company (Bureau Veritas, SGS, Intertek) can be attended and witness to the needed tests in order to ensure 100% complete matching between the product and what is required in tender or contract documents in terms of standards, specifications and conditions.

Third Party Inspection report could be provided to the purchaser with results of all tests performed including visual, quality, quantity, packing, marking, loading control and witnessing to hydrostatic tests, error of indication tests during the inspection before each shipment.

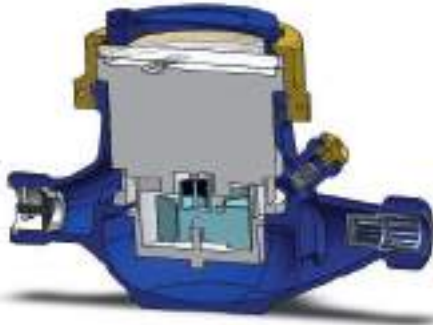

## Legibility & Reliability:

### • Register / Counter

The register is direct straight reading type and consists of five (5) digits numeric rolls for m<sup>3</sup> and four (4) pointers circular for litres to ensure perfect readability. The lowest resolution is 0,05 litres. The dial has a central disc (black or red) whose rotation indicates the passage of water. This indicator can be used to reveal a downstream leak. The register is also suitable for test on an electronic test bench.

The register is wet dial and hermetically sealed (IP68) with magnetic transmission. It registers in cubic meter units and protected by a resistant lid. The pivot of impeller chamber, turbine which is supported by a sapphire and rested on a stainless steel shaft are made to guarantee against any corrosion or damage.

### • Meter Body / Housing

The body/housing of the water meter, threaded type, made of brass alloy (press or cast) containing not less than 58% copper- corrosion protected by epoxy powder coating both inside and outside. A visible arrow on both sides of the body shows the direction of water flow.

### • Register Ring (Cap)

Register Ring (Cap) made of press brass alloy containing not less than 58% copper. The material can be accessible or removable in order to maintain the internal parts of the meter. Manufacturer's meter serial number are engraved on the register ring (Cap) covering the meter.

### • Register Protective Cover (Glass) and Register Cover (Lid)

The register protective cover is made of sturdy mineral glass to avoid condensation or enable the reading anyway, has a thickness of min. 5 mm which prevents any mechanical tempering and scratch resistance. The magnetic transmission interface is tamper-proof (protection from external magnetic influences). The protection of register mineral glass (lid) is 360° rotating and made of hard polymer.

### • Strainer and Non-Return Valve

Larger particles (dust, stone, etc.) in water can be filtered by a cleanable tubular, durable internal removable strainer at the flow inlet to the meter, without dismantling the meter and/or braking the seal. Durable internal non-return valve is integrated at meter body/housing at outlet-side.

### • Connector For Meter

Set of connectors for water meter comes with a set of klinger-seal or EPDM rubber gaskets and one set of brass couplings (tailpieces, nut) threaded to correct male size that are resistant to corrosion. The thread conform to ISO 228-1 standard.

Optional: (2) Coupling nut on tailpiece can be drilled for sealing wires.

	MATERIAL
1	BODY (BRASS)
2	LID
3	REGISTER CAP (BRASS)
4	GASKET
5	GLASS
6	REGISTER
6.1	ANTIMAGNETIC METAL RING
7	GASKET
8	TURBINE / VANE WHEEL
9	MEASURING CHAMBER
10	ADJUSTING SCREW
11	ADJUSTING PLUG
12	STRAINER
13	NON - RETURN VALVE

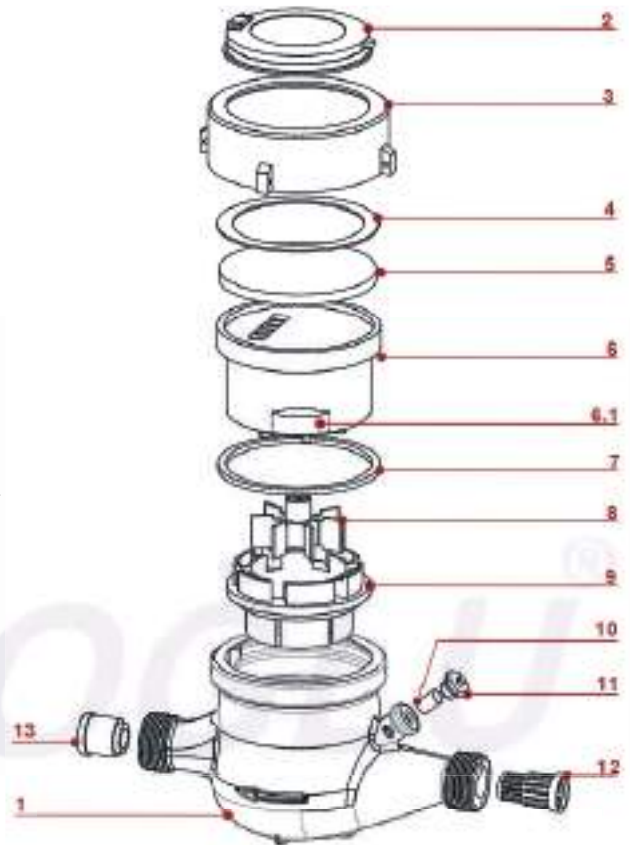

(1) Connector without hole for sealing (2) Connector with hole for sealing