

MERCAN Serie (DN25, DN32, DN40, DN50) Multi-Jet Dry Dial Water Meter for Cold Water

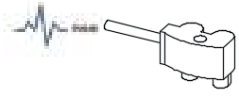

Main Characteristics:

Approved in accordance with MID
Multi-Jet dry dial register type with vane-wheel
Brass housing material
Durable internal removable strainer and non return valve
Removable measuring mechanism
Metrological range -horizontal- R100 (Class B)
360° rotating lid
Horizontal installation
Magnetic transmission
Register cap two parts made of brass
High resistance to water impurities
Hermetically sealed register (IP68)
Available for optical direct reading
Electrostatic e/p powder painted
External adjustable screw
(QR) Code to send data for viewing - optional
Water temperature up to 50°C
Equipable with Pulse output, MBus (Wire, Wireless), RF
Spare parts and service available for 10 years
2 years of guarantee

Available options:

The meter could be pre-equipped for future integration of remote reading devices such as MBus wire, MBus wireless OMS, Non-magnetic pulse output, AMR and upon request LoRa, LoRaWAN, Sigfox

Approvals:

EC type-examination certificate in conformity with

- 2014/32/EU (MID) MI-001 Water Meter
- OIML R49-1 :2006
- EN 14154:2005+A2
- ISO 4064:2015
- EC Type Examination Certificate (RO - 2275- 15286)
- The Quality Assurance of Production Process (Module D)
- Sanitary Compliance or Health Certificate (WRAS)
- ISO 9001:2015
- ISO 14001:2015
- ISO 45001:2018
- ISO 27001:2013

Applications:

For the consumption measuring of cold potable water up to 50°C. Working pressure 16 bar (PN16), min. static pressure test 25 bar for 15 mins., 32 bar for 1 mins. Its reliability, resistance to bad water quality and noiseless operation will satisfy both end users and network managers. Meter also keeps its metrological accuracy for many years of operation, even in very difficult working conditions.

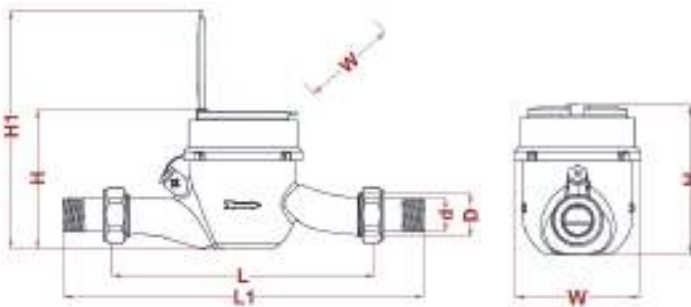

Dimension / Weight	Nominal Diameter	Dn Size	25		32		40		50	
			mm	Inch	mm	Inch	mm	Inch	mm	Inch
Overall Length Without Connectors	L	mm	260	1"	260	1"	300	1 1/4"	300	1 1/2"
Overall Length With Connectors	L1	mm	345,5	1 3/8"	341,45	1 3/8"	386,4	1 5/8"	400	1 5/8"
Thread Meter GxH	D	Inch	1 1/4"	1 1/4"	1 1/2"	1 1/2"	2"	2"	2 1/2"	2 1/2"
Thread Connector	d	Inch	1"	1"	1 1/4"	1 1/4"	1 1/2"	1 1/2"	2"	2"
Total Height	H	mm	115	4 1/2"	113,45	4 1/2"	142	5 5/8"	142	5 5/8"
Total Height (With Lid)	H1	mm	180	7 1/8"	180	7 1/8"	210	8 1/4"	210	8 1/4"
Width Approx	W	mm	90,3	3 5/8"	90,3	3 5/8"	110	4 3/8"	110	4 3/8"
Weight Approx	*	kg	2,05	4,5	2,03	4,5	4,30	9,5	4,65	10,2
Package Without Connectors	*	kg	2,15	4,7	2,14	4,7	4,45	9,7	4,80	10,5
Package With Connectors	*	kg	2,50	5,5	2,54	5,5	5,05	11,0	5,76	12,6
Box Dimension (1 unite)	*	cm	27x14x11		27x14x11		31x17x14		31x17x14	
Package Dimension (10 unite)	*	cm	57x28x15		57x28x15		44x33x20		44x33x20	
Quantity Per Package	*	unite	5		5		3		3	

Threading : EN ISO 228-1 : 2003

Marking:

The manufacturer's trade mark, Nominal flow rate (Q3), Metrological ratio (R), Nominal size of the meter, Maximum working pressure (MAP), Pressure head loss class (ΔP), Type of the meter (Model), EC-type examination certificate number, Year of manufacturing, Mounting position, Maximum water temperature (T), CE marking, Metrology marking, Notified body number from D and F module, Volume unite of the index (m3) according to the MID 2014/32/EU directive on measuring instruments are printed on the dial.

Optional customized meter marking purchaser's logo or tender number, or QR code, serial number.

Markings which are clearly visible, readable and of permanent and non-deleteable nature may vary depending on particular markets or metrological specifications.



Installation and Operating Instruction:

Meter must be installed in a low point of the pipeline with the arrow cast on the body showing direction of the water flow. All pipework must be flushed out to remove all impurities before fitting the water meter. An upstream stop valve or ball valve is recommended to allow installation and removal of the water meter. When connecting the meter with the meter network, the upstream stop valve or ball valve must be opened slowly so that the meter fills the meter as smoothly as possible. No special maintenance is required.

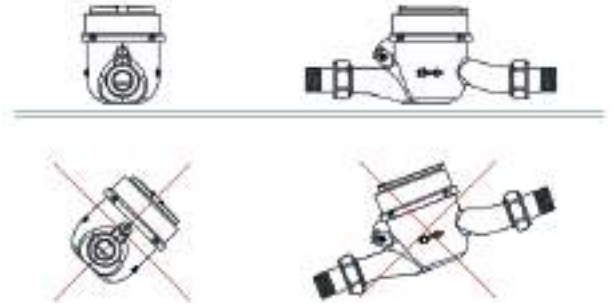

Pulse Emitter Device:

Water meter could be equipped with pulse emitter device which is a removable bonnet for quick and easy maintenance without damaging or removing the metrological seals of the meter. The meter can be linked to tele-reading systems, to PLC, to M-Bus networks using singal converter, to pulse counter and all those applications that require remote reading of the water consumption data.

Water meters could be equipped with a pulse emitter with protection class (IP68) 1,20 meter length of pre-mounted wire cables, Mercan (P) retrofittable with reed pulser: 100/1000 (Standard: 100 l/pulse, optional: 1000 l/pulse) or pre-equipped for the future installation of the pulse emitter. Note: The register protective cover of water meter with pulse emitter device will be high-quality UV-resistant and made of polycarbonate (PC) transparent material instead of mineral glass.

Typical Accuracy Curve:

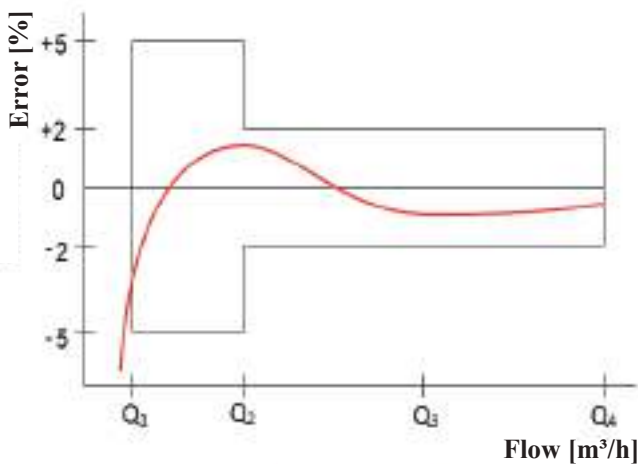

Q₁ = Minimum Flowrate Q₃ = Permanent Flowrate
 Q₂ = Transitional Flowrate Q₄ = Overload Flowrate

Typical Head Loss Curve:

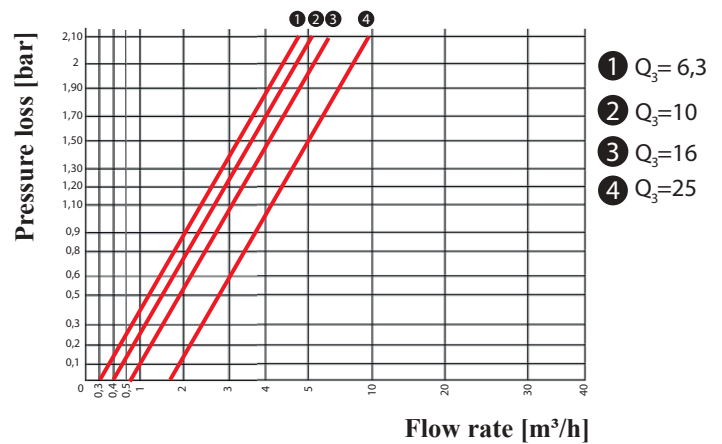

Tampering Protection and Sealing (Optional):

• Anti-Tampering butterfly seal for water meter

Pented butterfly seal consists mainly of three parts: transparent body, colored butterfly inner part and stainless steel sealing wire. Transparent body is made of polycarbonate (PC) material, colorful butterfly inner part is made of polyoximethylene (POM) which can not be removed without breaking from mounted inside. The inner part mounted inside the cylindrical body shall be non-reversible and unidirectional. Sealing wire made of AISI304 stainless steel are produced by twisting 7 pieces of Ø 0.23mm wire on top of each other. The butterfly seal can be used once against tampering in water meters. Optional: Laser printed serial number and company logo could be added on the body based on quantity.

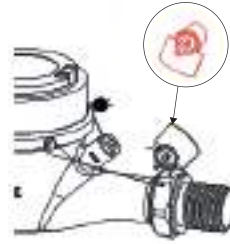

• Anti-Tampering plastic seal for water meter connectors

Plastic seal consists of two equal parts. They are made of polycarbonate (PC) material which has non-flammable, chemicals, salts, weather and ultra-violet resistant. Thickness is min.2,00 mm and not easily deform and it can not opened without breaking. There are holes on the locking mechanism suitable for the passage of the sealing wire after locking.

The materials to be used of both seals are recyclable, and the contents are not contain harmful substances to human health and environment.

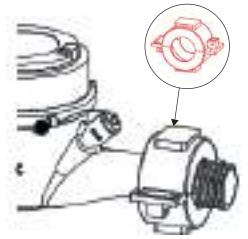

• Meter Seal

Sealing materials which are stainless steel wire 1.00 mm thickness - optional (covered with plastic) and aluminium seal.

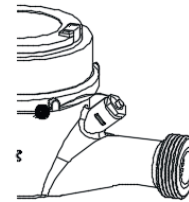

Stainless Steel Seal

	Nominal Daimeter (DN)	DN	mm	25	32	40	50
		Size	Inch	1"	1" ¼	1" ½	2"
Performance Data	Metrological Data	Maximum Flow Rate (m³/h)	Q4	≤7.88	≤12.5	≤20	≤31,3
	Nominal Flow Rate (m³/h)	Q3	≤6.30	≤10	≤16	≤25	
	Transitional Flow Rate (l/h) Tolerance ±2%	Q2	≤0.10	≤0.16	≤0.256	≤0.40	
	Minimum Flow Rate (l/h) Tolerance ±5%	Q1	≥0.063	≥0.010	≥0.016	≥0.025	
	Measuring Range - Horizontal (R-Class)	Q3 / Q1	100 H (Class B)				
	Measuring Transitional Flow Rate	Q2 / Q1	1.6				
	Measuring Maximum Flow Rate	Q4 / Q3	1.25				
	Accuracy Class		2				
Technical Data	Maximum Permissible Error Fort The Lower Flow Rate Zone	(MPE1)	±5%				
	Maximum Permissible Error Fort The Upper Flow Rate Zone	(MPEu)	±2 % for water having a temperature ≤30 °C ±3 % for water having a temperature >30 °C				
	Temperature Class	T °C	T30 and T50				
	Water Pressure Classes	MAP (Bar)	16				
	Pressure - Loss Classes	Δ P (Bar)	0,63				
	Max. Indicating Range	[m³]	99 999			999 999	
	Resolution Of The Indicating Device	[litre]	0,05				
	Instalation Positions		H				
	Flow Profile Sensitivity Classes		U0 , D0				
	Impulse Value	litre/pulse	100 , 1000				
ModuleType (Optional)		Pulse, MBus (Wired,Wireless), RF, AMR					

Third Party Inspection Company (Optional)

Third Party Inspection company (Bureau Veritas, SGS, Intertek) can be attended and witness to the needed tests in order to ensure 100% complete matching between the product and what is required in tender or contract documents in terms of standards, specifications and conditions.

Third Party Inspection report could be provided to the purchaser with results of all tests performed including visual, quality, quantity, packing, marking, loading control and witnessing to hydrostatic tests, error of indication tests during the inspection before each shipment.

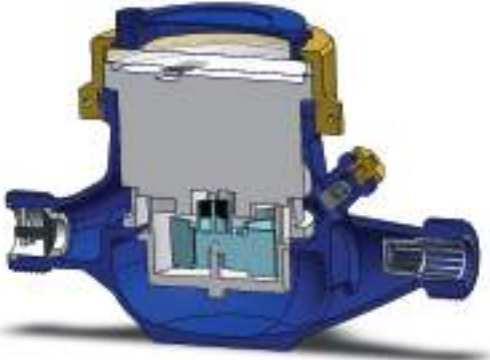

Legibility & Reliability:

• Register / Counter

The register is direct straight reading type and consists of five (5) digits numeric rolls for m³ for DN25 and DN32 (6 digits numeric rolls for m³ for DN40 and DN50) and four (4) pointers circular for litres to ensure perfect readability. The lowest resolution is 0,05 litres. The dial has a central disc (black or red) whose rotation indicates the passage of water. This indicator can be used to reveal a downstream leak. The register is also suitable for test on an electronic test bench.

The register is extra-dry dial and hermetically sealed (IP68) with magnetic transmission. It registers in cubic meter units and protected by a resistant lid. The pivot of impeller chamber, turbine which is supported by a sapphire and rested on a stainless steel shaft are made to guarantee against any corrosion or damage. Suitable for pre-equipped or equipped for the communication.

• Meter Body / Housing

The body/housing of the water meter, threaded type, made of brass alloy (press or cast) containing not less than 58% copper- corrosion protected by epoxy powder coating both inside and outside. A visible arrow on both sides of the body shows the direction of water flow.

• Register Ring (Cap)

Register Ring (Cap) made of press brass alloy containing not less than 58% copper. The material can be accessible or removable in order to maintain the internal parts of the meter. Manufacturer's meter serial number are engraved on the register ring (Cap) covering the meter.

• Register Protective Cover (Glass) and Register Cover (Lid)

The register protective cover is made of sturdy mineral glass to avoid condensation or enable the reading anyway, has a thickness of min. 5 mm which prevents any mechanical tempering and scratch resistance. The magnetic transmission interface is tamper-proof (protection from external magnetic influences). The protection of register mineral glass (lid) is 360° rotating and made of hard polymer.

• Strainer and Non-Return Valve

Larger particles (dust, stone, etc.) in water can be filtered by a cleanable tubular, durable internal removable strainer at the flow inlet to the meter, without dismantling the meter and/or braking the seal. Durable internal non-return valve is integrated at meter body/housing at outlet-side.

• Connector For Meter

Set of connectors for water meter comes with a set of klinger-seal or EPDM rubber gaskets and one set of brass couplings (tailpieces, nut) threaded to correct male size that are resistant to corrosion. The thread conform to ISO 228-1 standard.

Optional: (2) Coupling nut on tailpiece can be drilled for sealing wires.

	MATERIAL
1	BODY (BRASS)
2	LID
3	REGISTER CAP (BRASS)
4	GASKET
5	GLASS
6	REGISTER
6.1	ANTIMAGNETIC METAL RING
7	GASKET
8	TURBINE / VANE WHEEL
9	MEASURING CHAMBER
10	ADJUSTING SCREW
11	ADJUSTING PLUG
12	STRAINER
13	NON - RETURN VALVE



(1) Connector without hole for sealing (2) Connector with hole for sealing